

Standard Equipment/Optional Equipment

Standard Equipment

Long tiller with low mounting point
 Fibre-glass reinforced tiller and tiller head (Grivory®)
 Exxtral® motor and battery cover
 Creep speed control (L12, L12i)
 Proportional speed control (L12, L12i)
 End-of-stroke resistance
 Storage compartments
 OptiLift® proportional lift system (L10, L12, L12i)
 Hand protection at rear of mast (polycarbonate or steel mesh)
 Multi-function display with hourmeter including scheduled maintenance, fault code and battery discharge indicator
 Key switch or LFM Go (PIN-code access)
 AC motor
 Linde LAC controller

CAN-bus architecture
 Electromagnetic brake
 Automatic parking brake
 Cushion rubber drive wheel
 Single polyurethane load wheels
 Fork length: 1150 mm
 Width over forks: 560 mm
 Initial lift (L12i)
 Built-in or built-out fork carriage
 Protection to -10°C
 Vertical 2 PzS-B battery change (L10B, L10, L12)
 Vertical 3 PzS-B battery change (L12i)
 Horn
 Clipboard

Optional Equipment

Drive wheels: polyurethane, wet grip, non marking cushion, treaded cushion
 Load wheels: Tandem polyurethane, tandem polyurethane greasable
 Alternative fork lengths and widths
 Load backrest
 Creep speed control (L10)
 Proportional speed control (L10)

Linde Connected Solutions:
 ac:access control (PIN or RFID Dual), an:usage analysis and dt:crash detection
 Cold store protection to -35°C
 Automatic battery watering system
 Built-in charger
 High frequency charger

Other options available on request



Electric Pallet Stackers Capacity 1000 - 1200 kg L10B, L10, L12, L12i

Series 1172

Linde Material Handling



Safety

The hand guards of the off-centred tiller head effectively shield hands and keep the operator safely within the truck's contours with excellent visibility through the mast. The long tiller mounted low down on the chassis ensures ample safety clearance between operator and truck.

Performance

The combination of a new AC motor and Linde LAC digital controller makes these pallet stackers highly efficient. Operating parameters can be adjusted to match any application. The OptiLift mast control assures accurate, fully proportional lifting as well as smooth and quiet operation.

Comfort

All controls on the ergonomic tiller head can be easily operated by either hand. A Creep speed button offers utmost manoeuvrability in confined areas. Proportional speed automatically alters traction speed in relation to the truck/operator distance. Finished in tactile materials, these stackers deliver accurate load handling for better productivity.

Reliability

Despite their visual appeal, these pallet stackers are rugged and durable. The mast channels are made from high grade rolled steel sections for strength and durability. Strong and long-lasting Exxtral® motor and battery cover protect the technical compartment from outside shocks. In addition, a built-out fork carriage with thinner forks is available to protect the mast when handling gitterboxes.

Service

It is not just about the truck in operation: a maintenance-free AC motor maximises uptime, reducing operating costs. All truck data is immediately and easily accessible to the service engineer via CAN-bus architecture. Fast, easy access to all internal components ensures service tasks are completed with a minimum of delay.

Features

Steering system

- Proportional speed control varies truck speed automatically in relation to the tiller angle for safe, comfortable and productive operation
- A Creep speed button ensures high manoeuvrability in confined areas when operating at low speeds with tiller in upright position
- End-of-stroke resistance on the tiller avoids accidental, abrupt braking
- Soft tiller fold-back slows down the tiller when returning into upright position, avoiding the tiller snapping on the motor cover

AC motor & Booster effect

- Powerful, smooth-running 1.2 kW AC motor
- Traction speed adjustable up to 6 km/h, laden or unladen
- Booster effect provides higher torque when additional power is needed
- No roll-back on hill starts



Braking system

- Highly efficient electro-magnetic brake applied by moving tiller to fully up or down position
- Automatic braking on releasing traction butterfly or by reversing direction
- Truck slows before coming to a stop, remaining under total control at all times



Tiller & Tiller head

- Off-set, ergonomic Grivory® tiller head ensures safety and visibility
- Long tiller with low mounting point provides safety clearance between operator and chassis
- Wrap-around hand protection
- Comfortable controls, operable with either hand and gloves



Chassis

- Compact, rounded shape avoids snagging
- Highly resistant, robust steel construction
- Low chassis skirt protects operator's feet

Lifting system

- OptiLift mast control provides accurate, fully proportional lifting as well as smooth and quiet operation
- Soft landing of the forks protects load when lowering
- Wide range of mast options available
- Choice of standard or built-out carriage depending on application
- Initial lift on L12i ensures easy crossing of ramps and dock levellers

Working station & Display

- Wide, deep storage compartment for shrink wrap, pens, markers etc.
- Durable and long lasting Exxtral® motor and battery cover
- Multi-function display as standard with hourmeter including scheduled maintenance, fault code and battery discharge indicator



Maintenance and CAN-bus architecture

- Zero maintenance, moisture and dust-proof 1.2 kW AC motor
- CAN-bus architecture enables fast, easy access to all truck data
- Individually adjustable parameters via diagnostic plug
- Rapid and convenient access to main components via front service panel



Technical Data according to VDI 2198

		LINDE					
		L10B	L10	L12	L12i		
Characteristics	1.1	Manufacturer	LINDE	LINDE	LINDE	LINDE	
	1.2	Model designation	L10B	L10	L12	L12i	
	1.2a	Series	1172	1172	1172	1172	
	1.3	Power unit	Battery	Battery	Battery	Battery	
	1.4	Operation	Pedestrian	Pedestrian	Pedestrian	Pedestrian	
	1.5	Load capacity/Load	Q (t)	1.0	1.0	1.2	1.2
	1.6	Load centre	c (mm)	600	600	600	600
	1.8	Axle centre to fork face	x (mm)	715 ¹⁾	695 ²⁾	695 ²⁾	780 / 709 ³⁾²⁾
	1.9	Wheelbase	y (mm)	1157	1157	1157	1362 / 1291 ³⁾
Weights	2.1	Service weight	(kg)	708	788	788	909
	2.2	Axle load with load, front/rear	(kg)	617 / 1091	654 / 1134	671 / 1317	744 / 1365
	2.3	Axle load without load, front/rear	(kg)	518 / 190	572 / 216	572 / 216	643 / 266 ⁴⁾
Wheels/Tyres	3.1	Tyres rubber, SE, pneumatic, polyurethane	V+P/P ⁵⁾	V+P/P ⁵⁾	V+P/P ⁵⁾	V+P/P ⁵⁾	V+P/P ⁵⁾
	3.2	Tyre size, front	Ø 230 x 75	Ø 230 x 75	Ø 230 x 75	Ø 230 x 75	Ø 230 x 75
	3.3	Tyre size, rear	2x Ø 85 x 100	2x Ø 85 x 100	2x Ø 85 x 100	2x Ø 85 x 85	2x Ø 85 x 85
	3.4	Auxiliary wheels (dimensions)	Ø 140 x 54	Ø 140 x 54	Ø 140 x 54	Ø 140 x 54	Ø 140 x 54
	3.5	Wheels, number front/rear (x = driven)	1x + 1 / 2	1x + 1 / 2	1x + 1 / 2	1x + 1 / 2	1x + 1 / 2
	3.6	Track width, front	b10 (mm)	518	518	518	518
	3.7	Track width, rear	b11 (mm)	380	380	380	380
Dimensions	4.2	Height of mast, lowered	h1 (mm)	2390	1940	1940	1996
	4.3	Free lift	h2 (mm)	1912	150	150	150
	4.4	Lift	h3 (mm)	1912	2924	2924	2424
	4.5	Height of mast, extended	h4 (mm)	2390	3402	3402	4868
	4.6	Initial lift	h5 (mm)	-	-	-	130
	4.9	Height of tiller arm in operating position, min/max	h14 (mm)	650 / 1190	650 / 1190	650 / 1190	650 / 1190
	4.15	Height, lowered	h13 (mm)	86	86	86	86
	4.19	Overall length	l1 (mm)	1768	1788	1788	1907
	4.20	Length to fork face	l2 (mm)	618	638	638	757
	4.21	Overall width	b1/b2 (mm)	800	800	800	800
	4.22	Fork dimensions	s/e/l (mm)	65 x 180 x 1150	65 x 180 x 1150	65 x 180 x 1150	65 x 180 x 1150
	4.24	Width of fork carriage	b3 (mm)	534	534	534	534
	4.25	Fork spread, min/max	b5 (mm)	560	560	560	560
	4.32	Ground clearance, centre of wheelbase	m2 (mm)	30	30	30	20 / 150 ³⁾
	4.33	Aisle width with pallet 1000 x 1200 across forks	Ast (mm)	2324 (1945) ⁶⁾⁷⁾	2333 (1965) ⁶⁾⁷⁾	2305 (1937) ⁶⁾⁷⁾	2480 (2061) / 2437 (2061) ³⁾⁶⁾⁷⁾⁸⁾
4.34	Aisle width with pallet 800 x 1200 along forks	Ast (mm)	2289 (2145) ⁶⁾⁷⁾	2304 (2165) ⁶⁾⁷⁾	2276 (2137) ⁶⁾⁷⁾	2421 (2261) / 2403 (2261) ³⁾⁶⁾⁷⁾⁸⁾	
4.35	Turning radius	Wa (mm)	1460	1460	1432 ⁹⁾	1641 / 1570 ³⁾⁹⁾	
Performance	5.1	Travel speed, with/without load	(km/h)	6 / 6	6 / 6	6 / 6	6 / 6
	5.2	Lifting speed, with/without load	(m/s)	0.09 / 0.2	0.1 / 0.2	0.11 / 0.225	0.11 / 0.225
	5.3	Lowering speed, with/without load	(m/s)	0.23 / 0.23	0.35 / 0.35	0.4 / 0.3	0.4 / 0.3
	5.8	Maximum climbing ability, with/without load	(%)	5.0 / 10.0	5.0 / 10.0	5.0 / 10.0	10.0 / 15.0
	5.9	Acceleration time, with/without load	(s)	8.0 / 7.0	8.0 / 7.0	8.3 / 7.0	8.3 / 7.0
	5.10	Service brake		Electro-magnetic	Electro-magnetic	Electro-magnetic	Electro-magnetic
Drive	6.1	Drive motor, 60 minute rating	(kW)	1.2	1.2	1.2	1.2
	6.2	Lift motor, rating at S3 15%	(kW)	0.9	1	2.5	2.5
	6.3	Battery according to DIN 43531/35/36 A,B,C,no		no	no	no	no
	6.4	Battery voltage/rated capacity (5h)	(V/Ah)	24 / 180 ⁹⁾	24 / 180 ⁹⁾	24 / 180 ⁹⁾	24 / 225 ¹⁰⁾
	6.5	Battery weight (± 5%)	(kg)	195	195	195	200
	6.6	Power consumption according to VDI cycle	(kWh/h)	0.7	0.8	1	1
Others	8.1	Type of drive control		LAC	LAC	LAC	LAC
	8.4	Noise level at operator's ear	(dB(A))	65	65	65	65

- 1) With Standard mast - 20 mm. Forks carriages with fork thickness s = 60 mm, preferred while using gitter box, are also available: the x dimension decreases of -44 mm for Simplex masts and -35 mm for Standard mast.
- 2) With Simplex masts + 20 mm, with Triplex masts - 57 mm. Forks carriages with fork thickness s = 60 mm, preferred while using gitter box, are also available: the x dimension decreases of -44 mm for Simplex masts and -35 mm for Standard and Duplex masts.
- 3) Without/with Initial lift
- 4) Forks lowered
- 5) Solid rubber + polyurethane / polyurethane
- 6) Calculated with VDI 2198 (VDI 3597)
- 7) Including a 200 mm (min.) operating aisle clearance.
- 8) With creep speed = tiller in vertical position
- 9) Trough number 95
- 10) Trough number 68

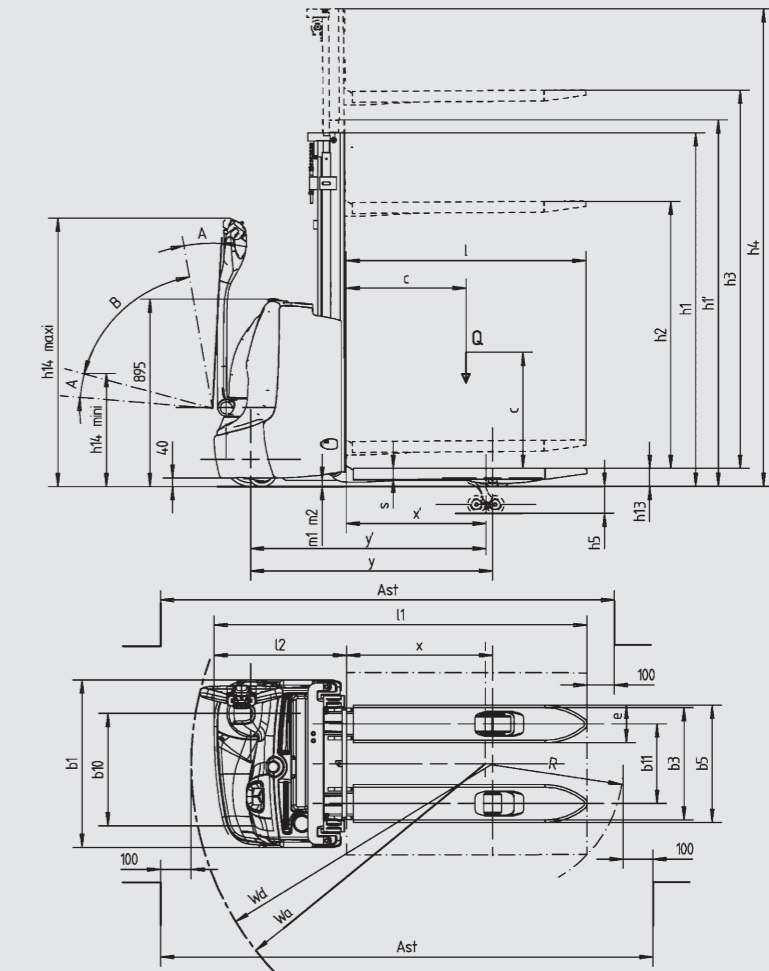

$$Ast = Wa + \sqrt{(l6 - x)^2 + \left(\frac{b12}{2}\right)^2} + a$$

$$Ast = Wa + R + a$$

Safety clearance a = 200 mm

Masts (L10/L12) (in mm)	1462 E	1912 E	2024 S	2424 S	2924 S	3324 S	3824 S	4224 S
Lift	h3	1462	1912	2024	2424	2924	3324	3824
Lift + fork height	h3+h13*	1547	1997	2109	2509	3009	4309	4309
Height lowered	h1*	1940	2390	1490	1690	1940	2140	2390
Height raised	h4	1943	2393	2502	2902	3402	3802	4702
Free lift	h2	1462	1912	150	150	150	150	150

Masts (L10/L12) (in mm)	2024 D	2424 D	2924 D	3324 D	3824 D	4224 D	3636 T	4386 T
Lift	h3	2024	2424	2924	3324	3824	4224	4386
Lift + fork height	h3+h13*	2109	2509	3009	3409	3909	3409	4471
Height lowered	h1*	1490	1690	1940	2140	2390	2590	1940
Height raised	h4	2502	2902	3402	3802	4302	4702	4868
Free lift	h2	1012	1212	1462	1662	1912	2112	1462

* Initial lift h5 = 130 mm
E=Simplex mast, S=Standard mast, D=Duplex mast, T=Triplex mast