

Standard Equipment/Optional Equipment

Standard Equipment

Long tiller with low mounting point
 Fibre-glass reinforced tiller and tiller head (Grivory®)
 Exxtral® motor and battery cover
 Creep speed control (T20)
 Proportional speed control (T20)
 End-of-stroke resistance
 Wide and deep storage compartments depending on battery size
 Multi-function display with hourmeter including scheduled maintenance, fault code and battery discharge indicator
 Key switch or LFM Go (PIN-code access)
 AC motor

Linde LAC controller
 CAN-bus architecture
 Electromagnetic brake
 Automatic parking brake
 Cushion rubber or polyurethane drive wheel
 Single polyurethane load wheels
 Fork length: 1150 mm
 Width over forks: 560 mm
 Protection to -10°C
 Vertical 2 PzS battery change
 Horn
 Clipboard

Optional Equipment

Drive wheels: wet grip, non marking polyurethane, treaded polyurethane, treaded cushion
 Load wheels: tandem polyurethane, single and tandem polyurethane greaseable
 Vertical 3 PzS (T18, T20) battery change
 Lateral 2 PzS (T16, T18, T20) and 3 PzS (T18, T20) battery change
 Mobile roller trolley (1 battery)
 Fixed roller trolley (2 batteries)
 Alternative fork lengths and widths
 Load backrest
 Creep speed control (T16, T18)
 Proportional speed control (T18)

Linde Connected Solutions:
 ac:access control (PIN or RFID Dual), an:usage analysis and dt:crash detection
 Cold store protection to -35°C
 Automatic battery watering system
 Built-in charger
 High frequency charger
 Castor wheels with springs & damper
 Additional emergency stop button
 Buzzer for noise sensitive areas
 Initial lift end stop

Other options available on request

Li-ION technology

Fast Full Charge
 Opportunity Charging
 Fast Intermediate Charging
 Maintenance Free
 Long Lifetime
 Good performance in Cold Store

Li-ION batteries

- fits in 2 PzS-B comp. (T16 ION, T18 ION): 1,8kWh-3,6kWh (24V/82-164Ah)
 - fits in 2 PzS comp. (T16 ION, T18 ION, T20 ION): 4,5kWh-9kWh (205-410Ah)
Optimized 24V-Li-ION charger
 - v90: 1,8kWh (82Ah); v160:3,6kWh (164 Ah)
 - v225: 4,5kWh-9kWh (205-410 Ah)



Electric Pallet Truck Capacity 1600, 1800 and 2000 kg T16, T18, T20

Series 1152

Linde Material Handling



Features

Steering system

- Proportional speed control varies truck speed automatically in relation to tiller angle for safe, comfortable and productive operation
- A Creep speed button ensures high manoeuvrability in confined areas when operating at low speeds with the tiller in the upright position
- End-of-stroke resistance on the tiller avoids accidental, abrupt braking
- Soft tiller fold-back slows down the tiller when returning into upright position, avoiding tiller snapping on the motor cover

Working station & Display

- Wide, deep storage compartment for shrink wrap, pens, markers etc.
- Strong and durable Exxtral® motor and battery cover
- Multi-function display with hourmeter including scheduled maintenance, fault code and battery discharge indicator



Braking system

- Highly efficient electromagnetic brake applied by moving the tiller to fully up or down position
- Automatic braking on releasing traction butterfly or reversing direction
- Truck slows before coming to a stop, remaining under total control at all times

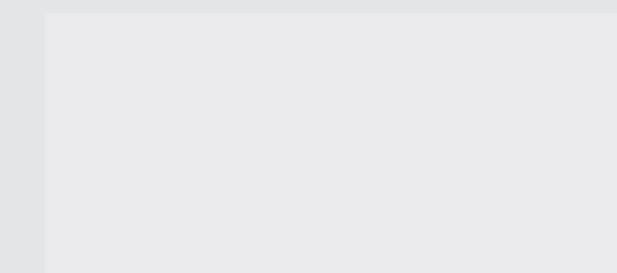

Chassis & Forks

- Compact, rounded shape
- Strong, robust steel construction
- Low chassis skirt to protect operator's feet
- Sturdy fork tips: each can support a load of 2,000 kg without bending
- Large castor wheels with shock absorbers for stability on ramps and uneven floors

Tiller & Tiller head

- The ergonomic Grivory® material ensures effortless operation
- Long tiller with low mounting point provides a large safety clearance between operator and chassis
- Wrap-around hand protection
- Comfortable controls, operable with either hand and gloves



Comprehensive energy solutions

- Wide range of lead acid batteries from 2.1kWh to 7.1kWh (150-375Ah) optionally with built in 35A charger, and side battery change on rollers
- Li-ION batteries from 1.8kWh to 9.0kWh (82-410Ah) with optimized charger

AC motor & Booster effect

- Powerful, smooth-running AC motor, 1.2 kW (at 100% output)
- Traction speed adjustable up to 6 km/h, laden or unladen
- Booster effect provides higher torque for additional power
- No roll-back on hill starts
- Gradient performance: 24% unladen, 10% with 2 t load

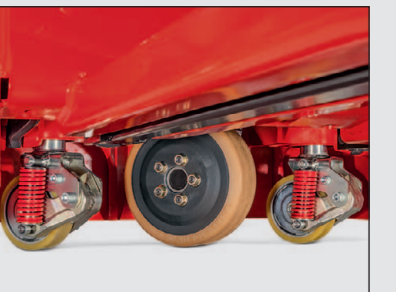

Maintenance/CAN-bus architecture

- Zero maintenance, moisture and dust-proof AC motor
- CAN-bus architecture enables fast, easy access to all truck data
- Individually adjustable parameters via diagnostic plug
- Rapid and convenient access to main components via front service panel

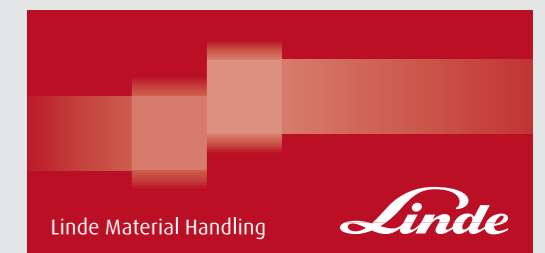

Linde Material Handling GmbH, Postfach 10 01 36, 63701 Aschaffenburg, Germany
 Phone +49.60 21.99-0, Fax +49.60 21.99-15 70, www.linde-mh.com, info@linde-mh.com

Subject to modification in the interest of progress. Illustrations and technical details could include options and not binding for actual constructions. All dimensions subject to usual tolerances.

Printed in Germany 117.e-4.0316.indd.KI

Technical Data according to VDI 2198

			LINDE	LINDE	LINDE	
Characteristics	1.1	Manufacturer		LINDE	LINDE	
	1.2	Model designation	T16 / [T16 ION]¹⁾	T18 / [T18 ION]¹⁾	T20 / [T20 ION]¹⁾	
	1.2a	Series	1152	1152	1152	
	1.3	Power unit	Battery	Battery	Battery	
	1.4	Operation	Pedestrian	Pedestrian	Pedestrian	
	1.5	Load capacity/Load	Q (t)	1.6	1.8	2.0
	1.6	Load centre	c (mm)	600	600	600
	1.8	Axle centre to fork face	x (mm)	890 / 962 ²⁾³⁾	890 / 962 ²⁾³⁾	890 / 962 ²⁾³⁾
	1.9	Wheelbase	y (mm)	1312 / 1378 ²⁾³⁾	1312 / 1378 ²⁾³⁾	1312 / 1378 ²⁾³⁾
Weights	2.1	Service weight	(kg)	421 [328] ¹⁾	485 [349] ¹⁾	582 [426] ¹⁾
	2.2	Axle load with load, front/rear	(kg)	681/1340 [591/1337] ¹⁾	748/1537 [650/1499] ¹⁾	874/1708 [749/1677] ¹⁾
	2.3	Axle load without load, front/rear	(kg)	327 / 94 [237 / 91] ¹⁾	350 / 135 [252 / 97] ¹⁾	432 / 150 [307 / 119] ¹⁾
Wheels/Tyres	3.1	Tyres rubber, SE, pneumatic, polyurethane		R+P/P ⁴⁾	R+P/P ⁴⁾	R+P/P ⁴⁾
	3.2	Tyre size, front		Ø 230 x 75	Ø 230 x 75	Ø 230 x 75
	3.3	Tyre size, rear		Ø 85x105 (Ø 85x100) ⁵⁾	Ø 85x105 (Ø 85x100) ⁵⁾	Ø 85x105 (Ø 85x100) ⁵⁾
	3.4	Auxiliary wheels (dimensions)		Ø 125 x 40	Ø 125 x 40	Ø 125 x 40
	3.5	Wheels, number front/rear (x = driven)		1x + 2 / 2 (1x + 2 / 4) ⁵⁾	1x + 2 / 2 (1x + 2 / 4) ⁵⁾	1x + 2 / 2 (1x + 2 / 4) ⁵⁾
	3.6	Track width, front	b10 (mm)	482	482	482
Dimensions	3.7	Track width, rear	b11 (mm)	355 / 395 / 515	355 / 395 / 515	355 / 395 / 515
	4.4	Lift	h3 (mm)	125	125	125
	4.9	Height of tiller arm in operating position, min/max	h14 (mm)	740 / 1208	740 / 1208	740 / 1208
	4.15	Height, lowered	h13 (mm)	88	88	88
	4.19	Overall length	l1 (mm)	1650	1725 [1650] ¹⁾	1800 [1725] ¹⁾
	4.20	Length to fork face	l2 (mm)	500	575 [500] ¹⁾	650 [575] ¹⁾
	4.21	Overall width	b1/b2 (mm)	720	720	720
	4.22	Fork dimensions	s/e/l (mm)	55 x 165 x 1150	55 x 165 x 1150	55 x 165 x 1150
	4.25	Fork spread, min/max	b5 (mm)	520 / 540 / 560 / 680	520 / 540 / 560 / 680	520 / 540 / 560 / 680
	4.32	Ground clearance, centre of wheelbase	m2 (mm)	36 / 161 ⁴⁾	36 / 161 ⁴⁾	36 / 161 ⁴⁾
4.33	Aisle width with pallet 1000 x 1200 across forks	Ast (mm)	1900 ⁷⁾⁸⁾⁹⁾	1975 [1900] ¹⁾⁷⁾⁸⁾⁹⁾	2050 [1975] ¹⁾⁷⁾⁸⁾⁹⁾	
4.34	Aisle width with pallet 800 x 1200 along forks	Ast (mm)	1950 ⁷⁾⁸⁾	2025 [1950] ¹⁾⁷⁾⁸⁾	2100 [2025] ¹⁾⁷⁾⁸⁾	
4.35	Turning radius	Wa (mm)	1440 / 1510 ⁷⁾⁷⁾	1515 / 1585 [1440 / 1510] ¹⁾⁷⁾⁷⁾	1590 / 1660 [1515 / 1585] ¹⁾⁷⁾⁷⁾	
Performance	5.1	Travel speed, with/without load	(km/h)	6 / 6	6 / 6	6 / 6
	5.2	Lifting speed, with/without load	(m/s)	0.035 / 0.044	0.033 / 0.044	0.034 / 0.044
	5.3	Lowering speed, with/without load	(m/s)	0.065 / 0.062	0.065 / 0.063	0.07 / 0.06
	5.8	Maximum climbing ability, with/without load	(%)	13.0 / 24.0	12.0 / 24.0	10.0 / 24.0
	5.9	Acceleration time, with/without load	(s)	7.4 / 6.4	7.5 / 6.4	7.6 / 6.4
	5.10	Service brake		Electro-magnetic	Electro-magnetic	Electro-magnetic
Drive	6.1	Drive motor, 60 minute rating	(kW)	1.2	1.2	1.2
	6.2	Lift motor, rating at S3 15%	(kW)	1	1	1.2
	6.3	Battery according to DIN 43531/35/36 A,B,C,no		2PzS-B [Li-ION]	43 535/B 2PzS [Li-ION]	43 535/B 3PzS [Li-ION]
	6.4	Battery voltage/rated capacity (5h)	(V/Ah)	24 / 150 [24 / 82] ¹⁾	24 / 250 [24 / 164] ¹⁾	24 / 375 [24 / 410] ¹⁾
	6.5	Battery weight (± 5%)	(kg)	157 [63]	212 [84]	288 [151]
	6.6	Power consumption according to VDI cycle	(kWh/h)	0.38	0.38	0.38
Others	8.1	Type of drive control		LAC	LAC	LAC
	8.4	Noise level at operator's ear	(dB(A))	<70	<70	<70

1) Figures in [] with Li-ION battery see line 6.4
 2) Forks upraised / lowered
 3) (+ 5 mm)
 4) Solid rubber + polyurethane / polyurethane
 5) Figures in parenthesis with tandem load wheels.

6) min./max.
 7) With creep speed = tiller in vertical position
 8) Including a 200 mm (min.) operating aisle clearance.
 9) With fork length 1150 mm

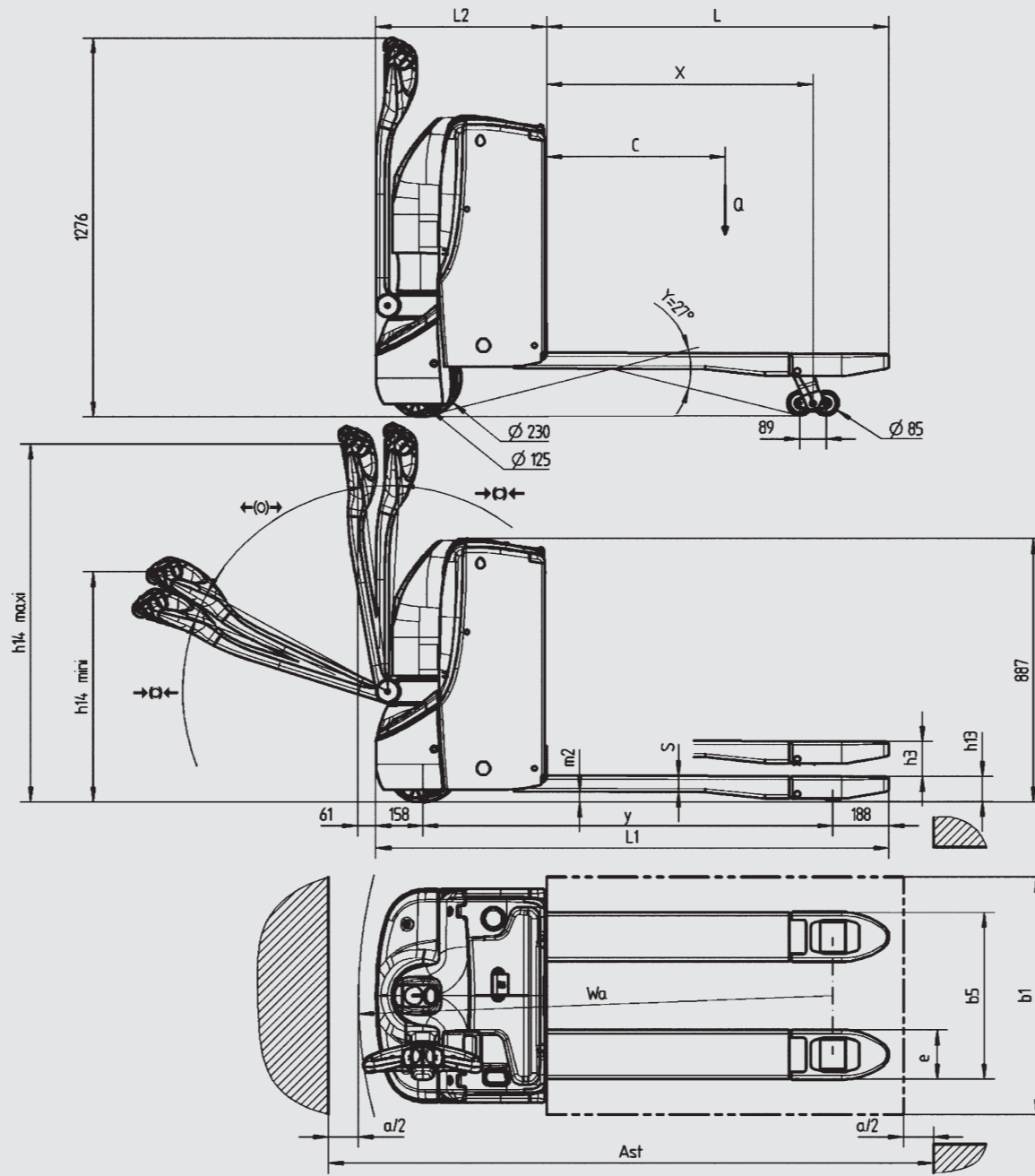

Battery compartment	Energy (kWh) Lead Acid [Li-ION]	Battery Capacity (Ah) Lead Acid [Li-ION]	Battery weight (kg) Lead Acid [Li-ION]	Dimension l2 (mm)	Dimension l1 (mm)	Fork length l (mm)	Turning radius Wa (mm)	Aisle width Pallet 800 x 1200 lengthwise	Aisle with Pallet 1000 x 1200 cross-wise	Full charging time for Li-ION width optimized charger
2-PzS-B*	2,66 [1,8/3,6]	150 [82/164]	140 [63/84]	500	1650	1150	1440	1950	1900	1h30min/1h30min
2-PzS	4,44 [4,5/9,0]	250 [205/410]	210 [110/151]	575	1725	1150	1515	2020	1975	1h30min/2h40min
3-PzS**	6,66	270-375	290	650	1800	1150	1590	2100	2050	-

*not available on the T20 ION / **not available on the T16 models

