

# Electric Rider Pallet Stacker 1200 and 1600 kg

Linde

L 12 R  
L 16 R



139-03

The L12R and L16R seated rider pallet stackers are designed both for transport and medium-height storage, up to 4724 mm lift height warehouses or workshops. The compact 4-point design provides excellent stability. Output is increased thanks to excellent ergonomics, visibility and high driving speeds.

#### Main Features

- 4-point for high residual capacities
- Compact chassis contributing to an excellent turning radius and low stacking aisle
- Clear view mast and fork carriage
- LDC electronic control (Linde Digital Control)
- Automatic electromagnetic braking
- Electric steering

#### Driver compartment

Functional driver's compartment with low access step. The specially designed seat supports every operational body movement, with adjustments to suit every operator.

The sideways seating position enables all-around visibility whether the truck is travelling forwards or backwards.

All controls are within easy reach, without having to lift the arm from the armrest.

This outstanding design makes for easy and safe driving.

Available with double pedal system, or with single pedal with direction switch.

#### Chassis

The chassis construction made of folded steel reduces the number of parts and optimises the welding, ensuring high rigidity and excellent reliability.

A large hinged door gives full access to the components for easy maintenance.

#### Transmission

Series wound 2.0kW motor directly mounted on a two stage and bevel gearbox. This unit enables high driving performance. The compact gear unit is mounted off-centered on the right and can rotate 180°.

#### Electric system

The truck is fitted with the advanced 24 V LDC drive control.

This MOS-FET controller provides exceptionally high acceleration and smooth operation.

Starts in gradients are safe as the LDC prevents the truck from rolling back. An automatic counter-current braking is applied when releasing the pedals (Linde brake control).

#### Electric steering

Smooth and precise LES-steering (Linde electrical steering) providing low effort and exceptional ergonomics. The position of the drive wheel is controlled by a microprocessor and a sensor. This construction ensures a constant and direct link between the position of the drive wheel and the steering wheel.

#### Wheels and pallet arms

The truck is fitted with an off-centre rubber drive wheel and a twin pivoting castor wheel. Polyurethane load wheels are equipped with a shrink-wrap protection. Various fork lengths are available.

#### Lifting

Compact, high output, low consumption motor-driven pump, including a 3.0kW motor (rating 15%) a high pressure gear pump, a 8-litre hydraulic tank.

#### Braking

Three independent braking systems

- Automatic counter-current braking when releasing the pedals (LBC)
- Foot operated electromagnetic brake on the drive motor
- Automatic parking brake applied when the driver steps of the truck

#### Safety

- Three independent braking systems
- No sharp edges
- Wheels turn within the confines of the chassis
- Excellent stability
- The operator is always protected within the contours of the driver compartment
- Check of all potential short-circuits at start-up
- Emergency stop button

Characteristics	1.1	Manufacturer		Linde	Linde
	1.2	Model designation		<b>L 12 R</b>	<b>L 16 R</b>
	1.3	Power unit: battery, diesel, petrol, LP gas, mains power		Battery	Battery
	1.4	Operation: manual, pedestrian, stand-on, seated, order picker		Seated Rider	Seated Rider
	1.5	Load capacity	Q (kg)	1200	1600
	1.6	Load centre	c (mm)	600	600
	1.8	Axle centre to fork face	x (mm)	703 (717) <sup>3)</sup>	666 (680) <sup>3)</sup>
	1.9	Wheelbase	y (mm)	1420	1420
	Weights	2.1	Service weight	kg	1560 <sup>1)</sup>
2.2		Axle load with load, front / rear	kg	1650/1110	1960/1200
2.3		Axle load without load, front / rear	kg	515/1045	1515/1045
Wheels and tyres	3.1	Tyres, front / rear (SE = Superelastic, P = Polyurethane)		G+P/P	G+P/P
	3.2	Tyre size, front		250 x 100	250 x 100
	3.3	Tyre size, rear		4 x 85 x 60	4 x 85 x 60
	3.4	Auxiliary wheels (dimensions)		2 x 125 x 45	2 x 125 x 45
	3.5	Wheels, number front / rear (x = driven)		1 x + 2/4	1 x + 2/4
	3.6	Track width, front	b <sub>10</sub> (mm)	653	653
	3.7	Track width, rear	b <sub>11</sub> (mm)	380	380
Dimensions	4.2	Height of mast, lowered	h <sub>1</sub> (mm)	1740 <sup>2)</sup>	1740 <sup>2)</sup>
	4.3	Free lift	h <sub>2</sub> (mm)	150 <sup>2)</sup>	150 <sup>2)</sup>
	4.4	Lift	h <sub>3</sub> (mm)	2424 <sup>2)</sup>	2424 <sup>2)</sup>
	4.5	Height of mast, extended	h <sub>4</sub> (mm)	2960 <sup>2)</sup>	2960 <sup>2)</sup>
	4.6	Initial lift height	h <sub>5</sub> (mm)	(130) <sup>3)</sup>	(130) <sup>3)</sup>
	4.7	Height of overhead guard (cabin)	h <sub>6</sub> (mm)	2050	2050
	4.8	Seat height	h <sub>7</sub> (mm)	910	910
	4.15	Fork height, lowered	h <sub>13</sub> (mm)	85	85
	4.19	Overall length	l <sub>1</sub> (mm)	2116 (2130) <sup>3)</sup>	2153 (2167) <sup>3)</sup>
	4.20	Length to fork face	l <sub>2</sub> (mm)	966 (980) <sup>3)</sup>	1003 (1017) <sup>3)</sup>
	4.21	Overall width	b <sub>1</sub> /b <sub>2</sub> (mm)	950	950
	4.22	Fork dimensions	s/e/l (mm)	55/180/1150	55/180/1150
	4.24	Width of fork carriage	b <sub>3</sub> (mm)	750	750
	4.25	Fork spread	b <sub>5</sub> (mm)	560	560
	4.31	Ground clearance, mast	m <sub>1</sub> (mm)	27	27
	4.32	Ground clearance, centre of wheelbase	m <sub>2</sub> (mm)	26	26
4.33	Aisle width with pallets 1000 x 1200 across forks	A <sub>st</sub> (mm)	2540 (2560) <sup>3) 4)</sup>	2550 (2570) <sup>3) 4)</sup>	
4.34	Aisle width with pallets 800 x 1200 along forks	A <sub>st</sub> (mm)	2510 (2520) <sup>3) 5)</sup>	2530 (2540) <sup>3) 5)</sup>	
4.35	Turning radius	W <sub>a</sub> (mm)	1670 (1695) <sup>3)</sup>	1670 (1695) <sup>3)</sup>	
Performance	5.1	Travel speed, with / without load	km/h	8.2/9.2	8.2/9.2
	5.2	Lifting speed, with / without load	m/s	0.138/0.200	0.138/0.200
	5.3	Lowering speed, with / without load	m/s	0.4/0.172	0.4/0.172
	5.7	Climbing ability, with / without load	%	3/7	3/7
	5.8	Maximum climbing ability, with / without load	%	12/17	12/17
	5.10	Service brake		Elektromagnetic	Elektromagnetic
Drive	6.1	Drive motor, 60 minute rating	kW	2.0	2.0
	6.2	Lift motor, 10% rating	kW	3.0	3.0
	6.3	Battery according to IEC		254-2	254-2
	6.4	Battery voltage / rated capacity (5 h)	V/Ah	24/440	24/440
	6.5	Battery weight (± 5%)	kg	377	377
	6.6	Power consumption in acc. with VDI cycle	kWh/h	-	-
Other	8.1	Type of drive control		LDC Digital Control	LDC Digital Control
	8.4	Mean noise level at driver's ear	dB(A)	78.6	78.6

1) With battery as per line 6.4.

2) For other masts see table.

3) In brackets for initial lift option. (L12Ri/16Ri models)

4) With previous calculation method, L 12 R = 2165 mm; L 16 R = 2203 mm.

5) With previous calculation method, L 12 R = 2365 mm; L 16 R = 2405 mm.

6) Forks 60x180x1150 available as an option with conventional carriage.

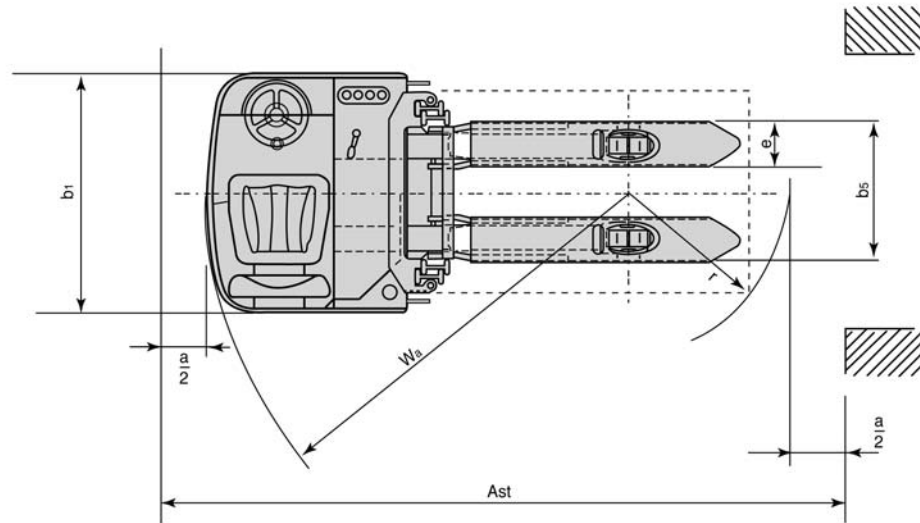
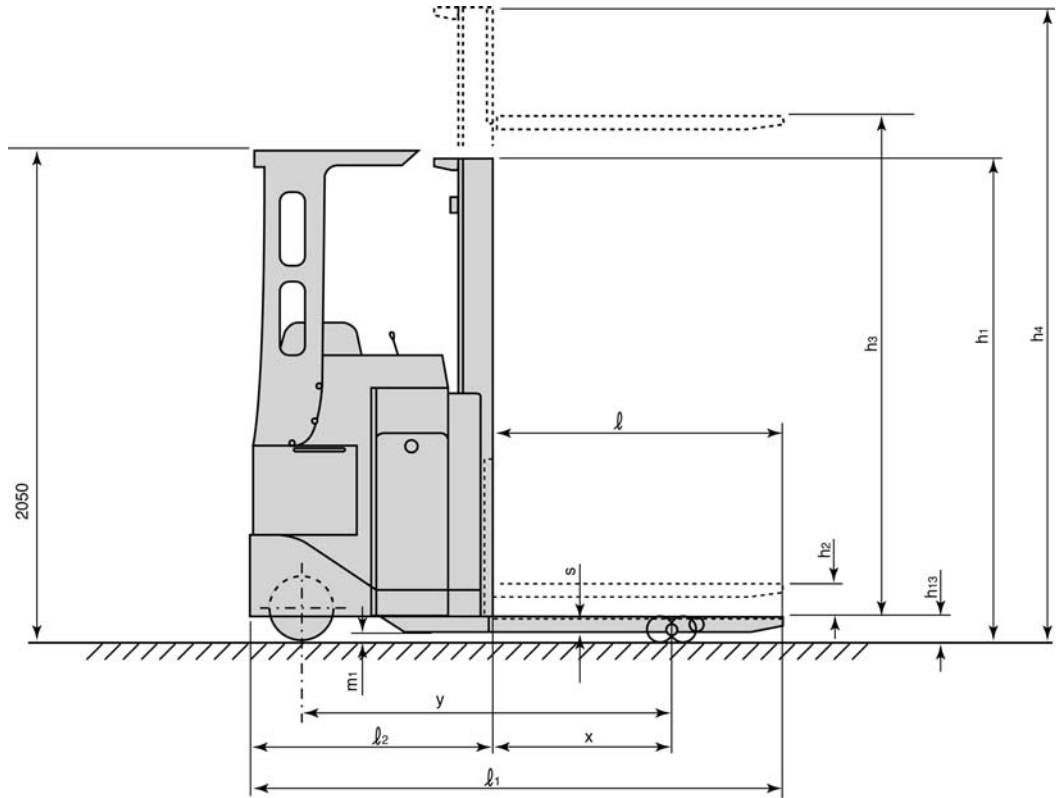

$A_{st} = W_a + r + a$   
 $a$ : operating clearance = 200 mm

<b>L 12 R</b>	Mast type		1462E	1924S	2424S	2924S	3324S	3824S	4224S	4724S	1924D	2424D	2924D	3324D	3824D	4224D
$h_3$	Lift	mm	1462	1924	2424	2924	3324	3824	4224	4724	1924	2424	2924	3324	3824	4224
$h_3+h_{13}$	Lift + fork height	mm	1548	2010	2510	3010	3410	3910	4310	4809	2010	2510	3010	3410	3910	4310
$h_1$	Height mast retracted	mm	1915	1440	1740	1990	2190	2440	2640	2890	1415	1665	1915	2115	2365	2565
$h_4$	Height mast extended	mm	1998	2460	2960	3460	3860	4360	4760	5260	2402	2902	3402	3802	4302	4702
$h_2$	Free Lift	mm	-	150	150	150	150	150	150	150	-	-	-	-	-	-
$h_2$	Special free lift	mm	-	-	-	-	-	-	-	-	962	1212	1462	1662	1912	2112

<b>L 16 R</b>	Mast type		1844S	2344S	2844S	3244S	3744S	4144S	4644S	1844D	2344D	2844D	3244D	3744D	4144D
$h_3$	Lift	mm	1844	2344	2844	3244	3744	4144	4644	1844	2344	2844	3244	3744	4144
$h_3+h_{13}$	Lift + fork height	mm	1929	2429	2929	3329	3829	4229	4729	1929	2429	2929	3329	3829	4229
$h_1$	Height mast retracted	mm	1440	1740	1990	2190	2440	2640	2890	1415	1665	1915	2115	2365	2565
$h_4$	Height mast extended	mm	2380	2880	3380	3780	4280	4780	5180	2380	2880	3380	3780	4280	4780
$h_2$	Free Lift	mm	150	150	150	150	150	150	150	-	-	-	-	-	-
$h_2$	Special free lift	mm	-	-	-	-	-	-	-	962	1212	1462	1662	1912	2112

Other mast configurations on request.

# Equipment

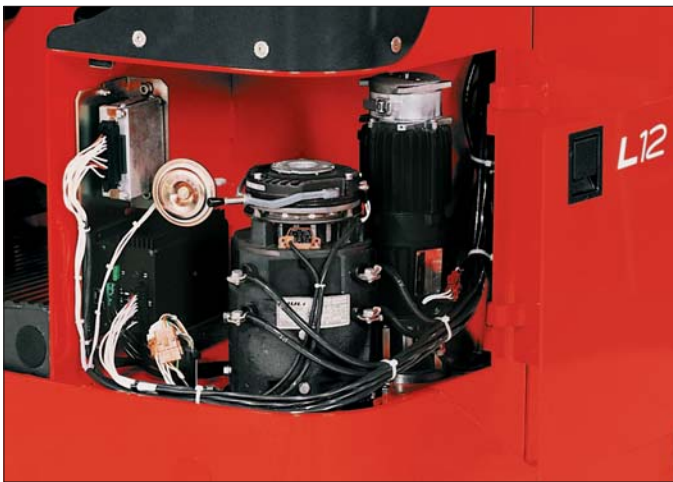

## Standard equipment

- Chassis width 950 mm
- Electric steering (LES)
- Forks: 560 mm x 1150 mm
- Rubber drive wheel and polyurethane twin castor wheel. Tandem polyurethane load wheels
- LDC drive control
- Horn, Key switch
- Emergency stop button
- Battery cable and plug
- Battery mounted on rollers for side removal
- Three independent braking systems, including automatic braking
- Operator's handbook and spare parts catalogue
- -10°C protection
- Truck complies with EC directives

## Battery and charger

- 24 V batteries with capacities ranking from 440 Ah bis 720 Ah are available
- Large choice of wall-mounted battery chargers

## Options

- Alternative mast types and heights (with or without free lift, up to 4809 mm total lift height)
- Alternative fork dimensions
- Single or double pedal system
- Polyurethane, non-marking or grooved rubber drive wheel
- Combined instrument: hourmeter and battery discharge indicator with lift cut-out
- Initial lift with level compensator (L12Ri/L16Ri models)
- Load backrest
- Working lamp
- Fabric driver seat or PVC seat with heating
- Battery trolley or stand for one or two batteries
- Supplementary battery cable and plug
- Supplementary set of documentation
- Cold store protection -30°C

Other options available on request.

Subject to modification in the interests of progress. Illustrations and technical details not binding for actual constructions. All dimensions subject to customary tolerances.