



# VERY NARROW AISLE A

## CAPACITY 1350 KG | SERIES 5022

### Safety

The new Linde A Man down range is a versatile VNA system truck designed for high density storage and retrieval of unit loads in very narrow aisles. In addition to modern, functional styling, the A range provides an environment in which the operator can work in complete comfort and safety.

### Performance

Intuitive use of the control panels enables throughput of goods to be increased without removing the hands. The operator can check the truck's status via the multifunctional display. Designed for low energy consumption, the truck also returns energy to the battery during braking and mast lowering.

### Comfort

A perfect interface between operator and truck has been achieved with the Linde ergonomic design concept, including spacious cab, comfort class seat and intuitive layout of all controls. The operators working environment ensures optimum performance.

### Reliability

Linde has used its vast experience in very narrow aisle applications, in conjunction with the latest technology available to ensure the new A range is a high quality product with exceptional product life. CAN bus diagnostics enable rapid fault finding and repair helping to achieve exceptional levels of truck uptime.

### Productivity

The unique modular design ensures that an individual truck specification can be tailored to match the application precisely in order to maximise productivity at all times. The smart electronics of Linde System Control (LSC) continuously monitors the truck's technical potential in order to deliver optimum simultaneous lift and travel speeds relative to lift height and load weight.

# TECHNICAL DATA

## ACCORDING TO VDI 2198

Characteristics	1.1	Manufacturer		LINDE	LINDE	LINDE
	1.2	Manufacturer's model designation		A	A	A
	1.3	Power unit		Battery	Battery	Battery
	1.4	Operation		Seated	Seated	Seated
	1.5	Load carrying capacity	Q (kg)	1000	1350	1350
	1.6	Load centre	c (mm)	600	600	600
	1.9	Wheelbase	y (mm)	1595	1739	1943
Weight	2.1	Weight (incl. battery)	kg	5114	5985	6634
	2.3	Axle loadings without load front/rear	kg	1855/3259	2176/3809	2531/4102
Wheels and types	3.1	Tyres		Polyurethane	Polyurethane	Polyurethane
	3.2	Tyre size, front	mm	360/140	360/140	360/140
	3.3	Tyre size, rear	mm	370/160	370/160	370/160
	3.5	Wheels, number front/rear (x = drive wheel)		1x/2	1x/2	1x/2
	3.6	Track width, front	b <sub>10</sub> (mm)	1290	1290	1290
	3.7	Track width, rear	b <sub>11</sub> (mm)	-	-	-
	Dimensions	4.2	Height of mast, lowered	h <sub>1</sub> (mm)	3400	3900
4.3		Free lift	h <sub>2</sub> (mm)	-	-	1650
4.4		Lift height	h <sub>3</sub> (mm)	4600	5200	5050
4.5		Height, mast raised	h <sub>4</sub> (mm)	6050	6650	6500
4.7		Height to top of overhead guard	h <sub>6</sub> (mm)	2200	2200	2200
4.8		Seat height	h <sub>7</sub> (mm)	1050	1050	1050
4.15		Fork height lowered	h <sub>13</sub> (mm)	60	60	60
4.19		Overall length (incl. forks)	l <sub>1</sub> (mm)	2884	3028	3232
4.21		Overall width	b <sub>1</sub> /b <sub>2</sub> (mm)	1250/1500	1250/1500	1250/1500
4.22		Fork dimensions	s/e/l (mm)	50/120/1200	50/120/1200	50/120/1200
4.23		Fork carriage to DIN 15173 / class / form A, B, no	(mm)	Special	Special	Special
4.24		Width of fork carriage	b <sub>3</sub> (mm)	710	710	710
4.25		Width of forks min./max.	b <sub>5</sub> (mm)	500/640	500/640	500/640
4.27		Width over side guide rollers	b <sub>6</sub> (mm)	1675	1645	1645
4.29		Lateral reach travel	b <sub>7</sub> (mm)	1400	1308	1308
4.31		Ground clearance beneath mast, laden	m <sub>1</sub> (mm)	40	40	40
4.32		Ground clearance at centre of wheelbase	m <sub>2</sub> (mm)	80	80	80
4.34		Aisle width	A <sub>st</sub> (mm)	1740	1650	1650
4.35		Turning radius	W <sub>9</sub> (mm)	1826	1970	2174
4.38		Centre of axle to fork pivot	l <sub>8</sub> (mm)	703	703	703
4.39		Head centre	A (mm)	480	480	480
4.40		Width of reach carriage	B (mm)	1560	1465	1465
4.41	Head width	F (mm)	250	250	250	
4.42	Transfer aisle width (min.)	A <sub>u</sub> (mm)	3346	3490	3694	
Performance	5.1	Travel speed, with/without load	km/h	10.5/10.5	10.5/10.5	10.5/10.5
	5.2	Lift speed, with/without load	m/s	0.56/0.70	0.51/0.55	0.52/0.55
	5.3	Lowering speed, with/without load	m/s	0.55/0.55	0.55/0.55	0.55/0.55
	5.4	Reach speed, with/without load	m/s	0.30/0.45	0.30/0.45	0.30/0.45
	5.9	Acceleration time, with/without load	s	5/5	6/6	6/6
	5.10	Brakes		Regenerative	Regenerative	Regenerative
Drive	6.1	Drive motor, Power	kW	6.5 kW / S <sub>2</sub> = 60 min	6.5 kW / S <sub>2</sub> = 60 min	6.5 kW / S <sub>2</sub> = 60 min
	6.2	Lift motor, Power	kW	24.0 kW / S <sub>3</sub> = 15 %	24.0 kW / S <sub>3</sub> = 15 %	24.0 kW / S <sub>3</sub> = 15 %
	6.3	Battery		IEC 254-2; C	IEC 254-2; C	IEC 254-2; C
	6.4	Battery type, voltage, capacity (5h)	V / Ah	PzS, 48 V, 700 Ah	PzS, 48 V, 980 Ah	PzS, 48 V, 1120 Ah
	6.5	Battery weight (±5%)	kg	1119	1498	1688
Others	8.1	Type of drive control		Microprocessor	Microprocessor	Microprocessor
	8.4	Noise level at operator's ear	dB (A)	68	68	68

Values can vary ±10%. The calculated speed profiles are based on our floor quality rules. Subject to change without notice.  
Exemplary configuration based on modular system. Please contact your local sales department for an individual truck configuration.

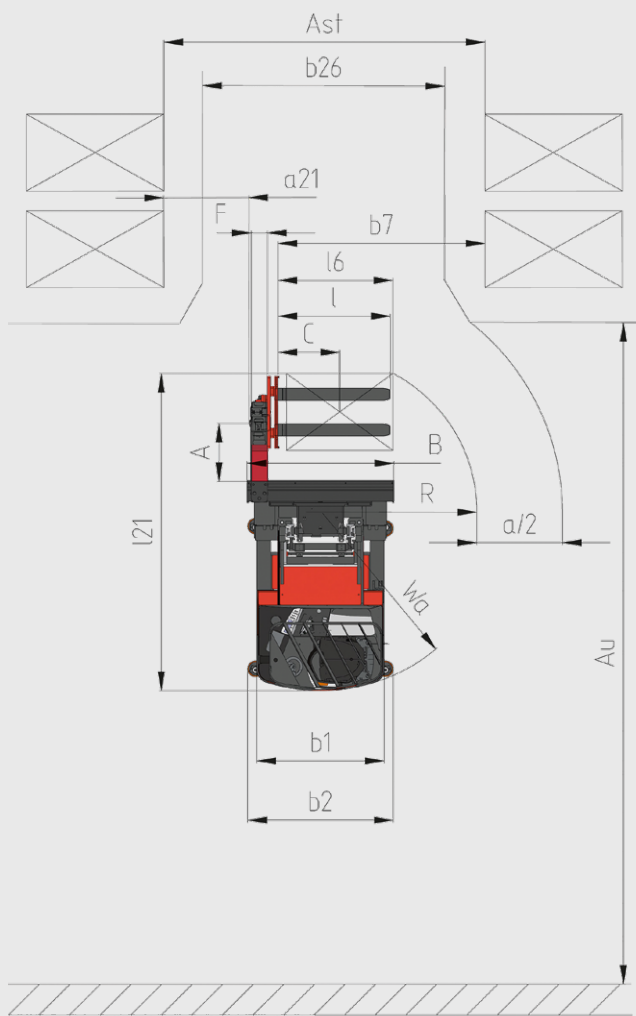
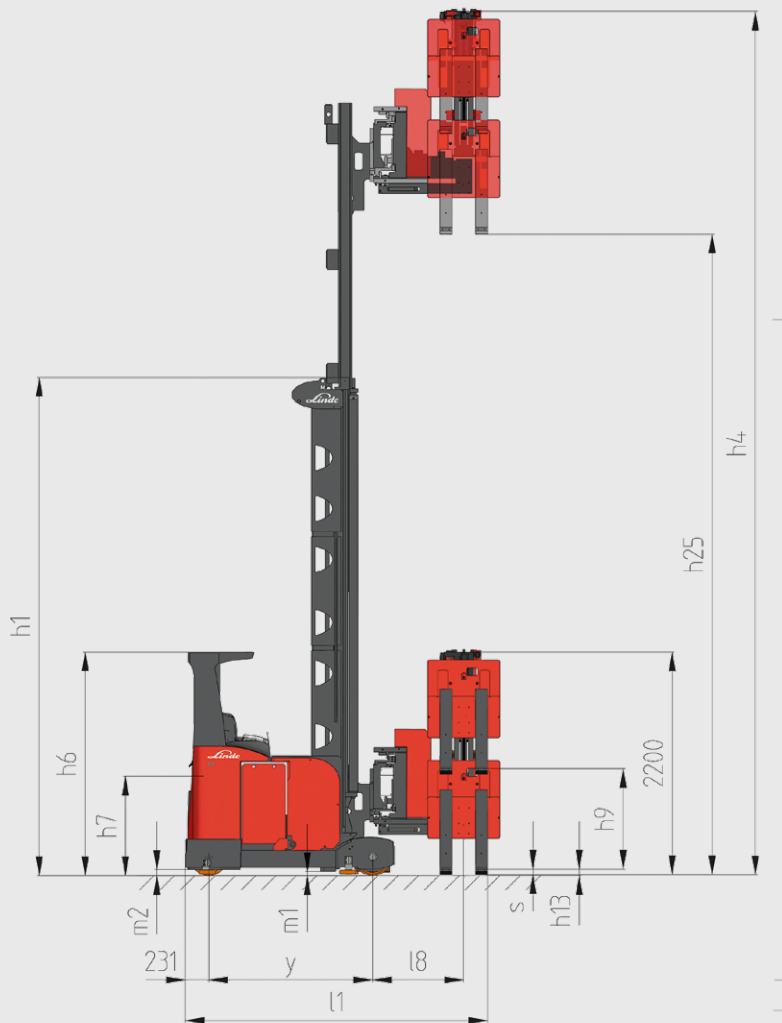

# MAST TABLES

Standard 1000 kg					
	Total lift above floor	Main lift	Height lowered	Auxiliary lift <sup>(2)</sup>	Max. height <sup>(1)</sup>
$h_1$	$h_{25}^*$	$h_3$	$h_{13}$	$h_9$	$h_4$
4900	8655	7600	60	995	9800
4400	7655	6600	60	995	8800
3900	6655	5600	60	995	7800
3400	5655	4600	60	995	6800
2900	4655	3600	60	995	5800
2400	3655	2600	60	995	4800
2200	3255	2200	60	995	4400

Standard 1350 kg					
	Total lift above floor	Main lift	Height lowered	Auxiliary lift <sup>(2)</sup>	Max. height <sup>(1)</sup>
$h_1$	$h_{25}^*$	$h_3$	$h_{13}$	$h_9$	$h_4$
4900	8255	7200	60	995	9400
4400	7255	6200	60	995	8400
3900	6255	5200	60	995	7400
3400	5255	4200	60	995	6400
2900	4255	3200	60	995	5400
2400	3255	2200	60	995	4400
2200	2855	1800	60	995	4000

Triplex 1350 kg						
	Total lift above floor	Main lift	Freelift	Height lowered	Auxiliary lift <sup>(2)</sup>	Max. height <sup>(1)</sup>
$h_1$	$h_{25}^*$	$h_3$	$h_2$	$h_{13}$	$h_9$	$h_4$
3900	8505	7450	2650	60	995	9650
3400	7405	6350	2150	60	995	8550
2900	6105	5050	1650	60	995	7250
2400	4605	3550	1150	60	995	5750
2200	4005	2950	950	60	995	5150

A <sub>st</sub> Data					
	Pallet size	Stacking depth	Ast	AU-min	Au-opt <sup>(3)</sup>
Euro	1200 × 800	1200	1630	3202	plus 500
Euro	800 × 1200	800	1275	3539	plus 500
Chep	1200 × 1000	1200	1630	3368	plus 500
Chep	1000 × 1200	1000	1430	3505	plus 500

\*  $h_{25} = h_3 + h_9 + h_{13}$

<sup>(1)</sup> Without auxiliary lift:  $h_4 - 750$  mm

<sup>(2)</sup> Without auxiliary lift:  $h_{25} - 995$  mm

<sup>(3)</sup> Values depend on guidance system.

For confirmation of AST and AU please contact your local sales and service dealer.

# STANDARD EQUIPMENT / OPTIONAL EQUIPMENT

## STANDARD EQUIPMENT

### Operators compartment:

Hydraulically damped operators fabric seat with weight, rake, lumbar support and longitudinal adjustment

Ergonomic multifunctional controls

Truck access via key

Low step in height for easy access to drivers compartment

Basic functions without changing position of grip

Multi purpose display with keypad

Storage compartments, pen holders and space for bottles, cans or tools integrated

Clear and distinct control layout

LCD Display (guidance / capacity / steer angle / battery and operating state / operating hours / lift height / speed / service info)

Side seated operation

All round visibility with the ergonomically designed overhead guard

Overhead guard with head cushion

### Throughput:

LSC standard

Synchronized lowering

Synchronous swivel

Energy recovery when braking or lowering the mast

### Mast/Forks:

L-head or telescopic forks

### Motors:

13 KW lift motor

6.5 KW drive motor

### Safety:

Warning light mounted on overhead guard (active during all movements)

## OPTIONAL EQUIPMENT

### Operators compartment:

Comfortable seats (heated, synthetic leather)

Wire mesh or makrolon overhead guard cover

Radio preparation

Rearview (left / right) and panorama mirror

Clipboard DIN A4

Lighting for operators compartment

Working lights into rack

Pin code access

Linde LFM management system

### Throughput:

LSC with load recognition, load sensor or weight and load recognition

Synchronous swivel with stop at 90 degrees

Automatic fork cyclus

Overreach facility of forks up to 55 mm

Twin pedal system

Pallet positioning aid

Lift height preselection

Loadwheel brake for increased travel speed

### Drive:

Different drive and lift motors available

Rail or wire guidance options

### Safety:

Different speed reductions and aisle stop functions

Personal safety equipment (PSE)

Lifting and driving cut off

Audible warnings

Camera systems for driving and pallet handling

### Mast/Forks:

Standard masts 1000 kg capacity up to 8655 mm lift height

Standard masts 1350 kg capacity up to 8255 mm lift height

Triplex masts 1350 kg capacity up to 8505 mm lift height

Auxiliary lift ( $h_0=995$  mm)

Alternative fork lengths for different pallet sizes

Manual or hydraulically adaptable forks

Gear rack cover for L-head

### Battery:

Alternative battery capacities

Battery mounted on rollers for side change

Battery roller stands

Electrical verification for battery lock

Cable for additional battery

### Environment:

Antistatic guide rollers

Antistatic for inductive guidance

### Service:

Online diagnosis tool

# FEATURES

## Cabin

- Side seated operation allows the truck operator to have excellent vision during both forward and reverse traction of the truck
- This driving position also allows the operator to park the truck in aisle, and exit the cab safely
- Comfortable working space for increased throughput
- Various comfortable and adjustable seat options
- Different storage compartment options are available to suit individual customer requirements



## Linde System Control (LSC)

- The Linde system control (LSC) represents a significant advance in the smart control of Man down VNA trucks
- LSC Standard 3.0. Dynamical diagram of residual capacity depending on the actual speed and lifting heights
- LSC with load recognition 3.1. Detection of load, additional lifting functions are adjusted
- LSC with load sensor 3.2. Detection of load, additional lifting functions are adjusted as well the driving parameters
- LSC with weight and load recognition 3.3. Driving profile depending on the actual transported weight plus the 3.1 optimization

## Modular concept

- Unique modular designed truck enable the perfect specification for each application
- Combination of different lift and drive motors, chassis, masts, batteries, cabins, etc. to suit each application

## Control concept and display

- The high contrasting LCD display gives excellent driver information
- Fatigue free working due to ergonomic positioned multifunction joystick
- The simple ergonomic controls allow precise, accurate function control, once again reducing driver fatigue and increasing truck throughput

## Mast

- Standard and triplex mast options are available up to 1350 kg capacity
- The slim mast design gives excellent vision when both stacking and retrieving pallets
- A rigid, strong mast design helps reduce mast sway, therefore increasing truck cycle times



## Drive and lift

- High performance AC drive and Lift motors are fitted as standard
- Optional motor sizes allow the truck performance to be matched to customer requirements

## Batteries

- Easy and quick battery change with truck battery rollers and static battery stands
- The modular system allows batteries from 465 to 1240 Ah to be fitted

## Camera and Positioning

- Optional positioning systems are available helping to give high throughputs
- Easier pallet handling at height through camera system
- Safe driving with camera

Subject to modification in the interest of progress. Illustrations and technical details could include options and not binding for actual constructions. All dimensions subject to usual tolerances.

Presented by:

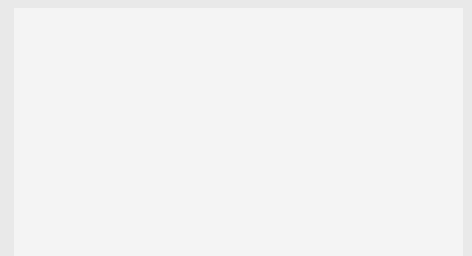

**Linde Material Handling GmbH**  
Carl-von-Linde-Platz | 63741 Aschaffenburg | Germany  
Phone + 49 6021 99 0 | Fax + 49 6021 99 1570  
www.linde-mh.com | info@linde-mh.com

Printed in Germany 053.e.1.0319.IndC.Ki